

DUST & STATIC

4510 IONISED AIR JETS

The 4510 Ionised Air Jet produces a fast, quiet, flat jet of ionised air for efficient static neutralisation and cleaning.

4510 Ionised Air Jets are used in many applications, including long distance static neutralisation, dust removal and cleaning, sheet separation.

- > Powerful and safe ionisation to overcome the most stubborn static electricity.
- > Low noise.
- > Economical airflow - entrains ambient air to produce a large volume airflow.
- > Flat concentrated airflow for intensive blow-off.
- > High thrust (airspeed x volume) for optimal cleaning.
- > Meets OSHA safety standards.
- > Easy to install stainless steel bracket.

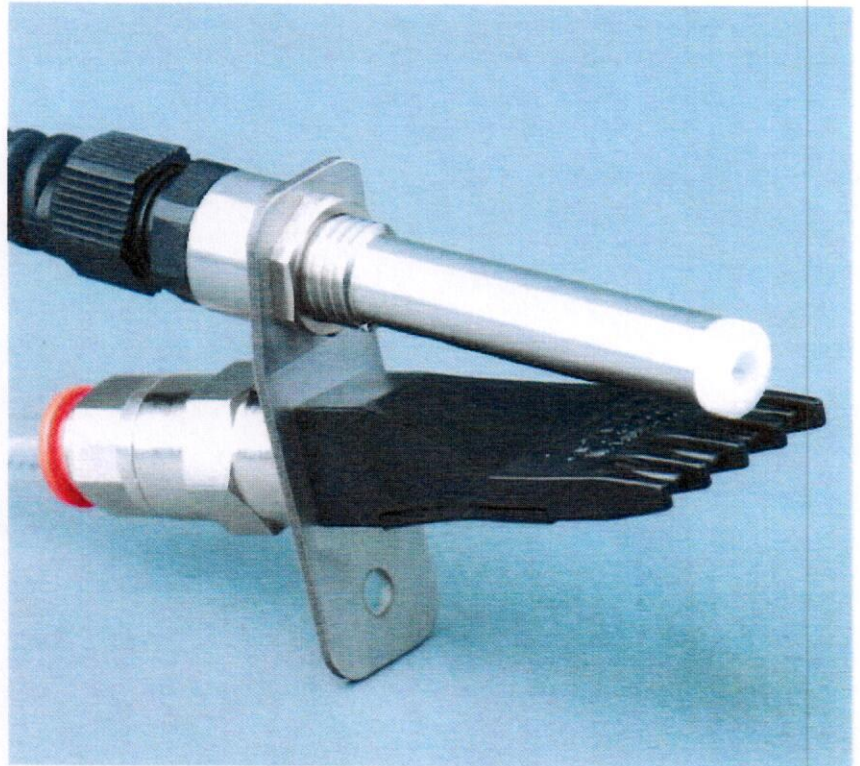

Specification

Construction:	Stainless Steel and PTFE.
Dimensions, Weight:	See sketch on Page 2.
Noise:	76dBA @ 7 Bar.
Air Pressure:	Maximum 7 Bar.
Air Consumption:	2 Bar: 180 l/min. 7 Bar: 520 l/min.
Environment:	-10° to 70°C. 70% rH non-condensing max.
Cable:	2m unless otherwise specified. 10m maximum.
Air Fitting:	1/4" Female thread.
Power Unit:	Fraser 5.5kV & 6kV Power Units.

BOUSSEY CONTROL EUROPE - Jacob Lacopstraat 36 Bus 101 - 9700 Oudenaarde - Belgium

☎ +32 55 423953 - 📠 + 32 55 612101

Email: info@boussey-control.eu – Site Internet: www.boussey-control.com

How it works:

Ionised air produced by the stainless steel ionisation tube is transported by the compressed air coming out of the black plastic jet towards the object. The ionisation neutralises the static charge, allowing the air to remove the contaminant, or separate the products etc.

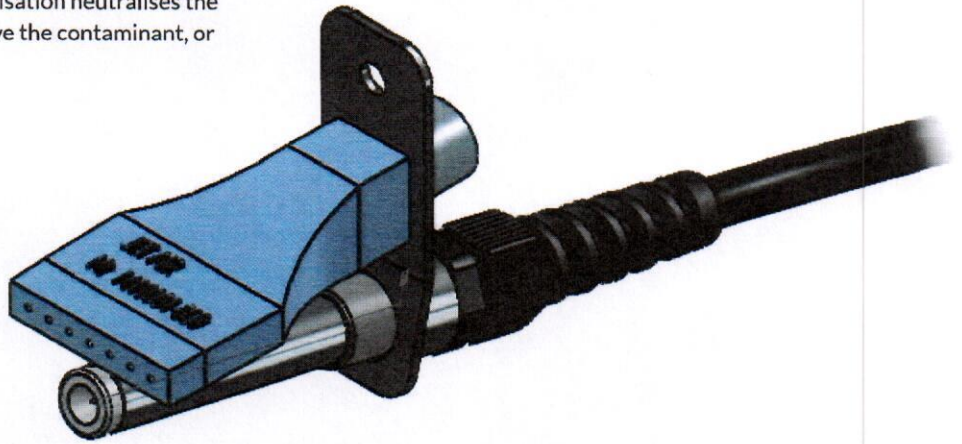

4510 Dimensions

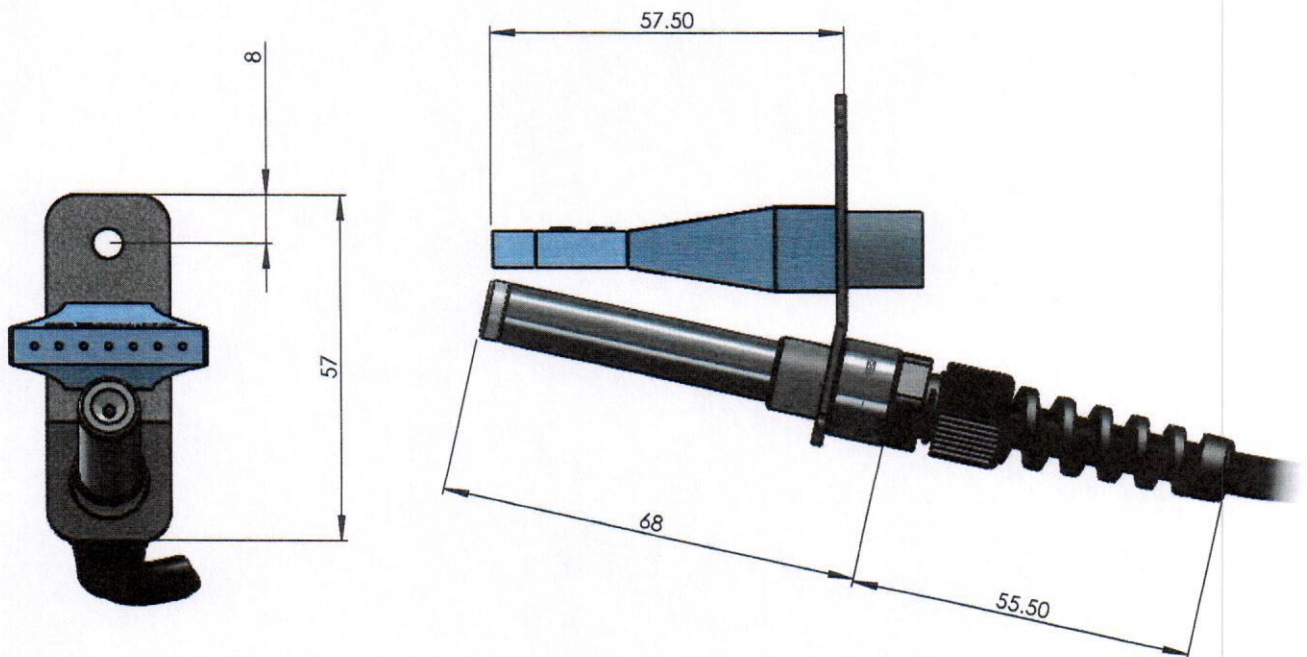

BOUSSEY CONTROL EUROPE - Jacob Lacopstraat 36 Bus 101 - 9700 Oudenaarde - Belgium

☎ +32 55 423953 - 📠 + 32 55 612101

Email: info@boussey-control.eu – Site Internet: www.boussey-control.com